



ISO9001 & ISO13485 & ISO11137

to prefilling.

7. Easy to be stored and transported.

8. Tailor-made for customers: Various specifications are available, customers can choose according to the required specifications. Special packaging customization is also available.

**Product Range**

| Cat. No. | Product Description         | /Pack | /Case |
|----------|-----------------------------|-------|-------|
| 207011   | 5 mL AccureVial™ COP Bottle | /     | 48    |

**Technical Drawing**

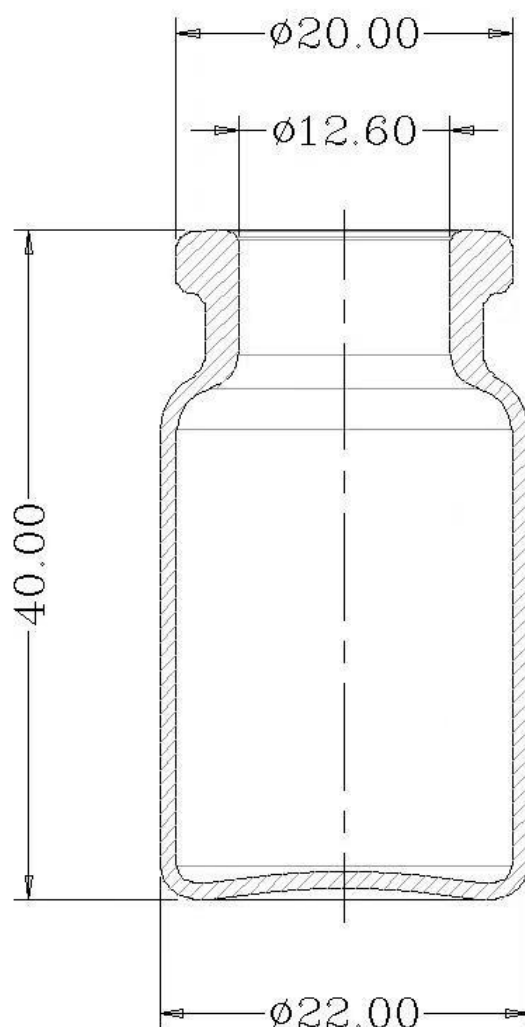

**Head Office** No. 530, Xida Road, Meicun Industrial Park, Xinwu District, Wuxi, Jiangsu, China  
 Tel: +86+ 510-6800 6788 Email: [info@nest-wuxi.com](mailto:info@nest-wuxi.com)  
 Online: [www.cell-nest.com](http://www.cell-nest.com)

**Oversea** NEST USA (New Jersey/ Phoenix)  
 NEST scientific 株式会社 (Yokohama, Japan)  
 NEST Scientific Europe B.V (Netherlands)  
 Nest Scientific (MENA) FZE (Sharjah, United Arab Emirates)